

## DEHN FILLING OF CUSPED HYPERBOLIC 3-MANIFOLDS WITH GEODESIC BOUNDARY

ROBERTO FRIGERIO, BRUNO MARTELLI &  
CARLO PETRONIO

### Abstract

We define for each  $g \geq 2$  and  $k \geq 0$  a set  $\mathcal{M}_{g,k}$  of orientable hyperbolic 3-manifolds with  $k$  toric cusps and a connected totally geodesic boundary of genus  $g$ . Manifolds in  $\mathcal{M}_{g,k}$  have Matveev complexity  $g + k$  and Heegaard genus  $g + 1$ , and their homology, volume, and Turaev-Viro invariants depend only on  $g$  and  $k$ . In addition, they do not contain closed essential surfaces. The cardinality of  $\mathcal{M}_{g,k}$  for a fixed  $k$  has growth type  $g^g$ .

We completely describe the non-hyperbolic Dehn fillings of each  $M$  in  $\mathcal{M}_{g,k}$ , showing that, on any cusp of any hyperbolic manifold obtained by partially filling  $M$ , there are precisely 6 non-hyperbolic Dehn fillings: three contain essential discs, and the other three contain essential annuli. This gives an infinite class of large hyperbolic manifolds (in the sense of Wu) with  $\partial$ -reducible and annular Dehn fillings having distance 2, and allows us to prove that the corresponding upper bound found by Wu is sharp. If  $M$  has one cusp only, the three  $\partial$ -reducible fillings are handlebodies.

### 1. Definition and statements

In this paper we introduce certain classes  $\mathcal{M}_{g,k}$  of compact 3-manifolds, we determine many topological and geometric invariants of the elements of  $\mathcal{M}_{g,k}$ , and we analyze their Dehn fillings, answering in particular a question raised by Wu [22] on the distance between non-hyperbolic fillings of a large 3-manifold. We also show that  $\#\mathcal{M}_{g,k}$  grows very fast as  $g$  goes to infinity.

**Definition of  $\mathcal{M}_{g,k}$**  All the manifolds considered in this paper will be viewed up to homeomorphism, and will be connected and orientable by

---

Received 01/23/2003.

default. Let  $\Delta$  denote the standard tetrahedron, and let  $\dot{\Delta}$  be  $\Delta$  with its vertices removed. An *ideal triangulation* of a compact 3-manifold  $M$  with boundary is a realization of the interior of  $M$  as a gluing of a finite number of copies of  $\dot{\Delta}$ , induced by a simplicial face-pairing of the corresponding  $\Delta$ 's. Let  $\Sigma_g$  be the closed orientable surface of genus  $g$ . The following result is proved in Section 2 and motivates our definition of  $\mathcal{M}_{g,k}$ .

**Proposition 1.1.** *An ideal triangulation of a manifold whose boundary is the union of  $\Sigma_g$  and  $k$  tori contains at least  $g+k$  tetrahedra.*

We then define  $\mathcal{M}_{g,k}$  for all  $g \geq 2, k \geq 0$  as follows:

$$\mathcal{M}_{g,k} = \left\{ \begin{array}{l} \text{compact orientable manifolds } M \text{ having an ideal} \\ \text{triangulation with } g+k \text{ tetrahedra, and} \\ \partial M = \Sigma_g \sqcup \left( \bigsqcup_{i=1}^k T_i \right) \text{ with } T_i \cong \Sigma_1 \end{array} \right\}.$$

The sets  $\mathcal{M}_g = \mathcal{M}_{g,0}$  were studied in [3].

**Geometric and topological invariants** We now describe the main properties of the manifolds in  $\mathcal{M}_{g,k}$ , starting from a quick general review of the invariants that we can compute.

We first recall that a surface in a compact 3-manifold  $M$  is *essential* if it is properly embedded, connected, and either a reducing sphere, or a boundary-reducing disc, or an incompressible and  $\partial$ -incompressible surface not parallel to the boundary.

We say that a compact 3-manifold  $M$  is *hyperbolic* if, after removing the boundary tori, we get a complete hyperbolic 3-manifold with finite volume and geodesic boundary. If  $\partial M \neq \emptyset$ , Thurston's geometrization theorem implies that hyperbolicity is equivalent to the condition that  $M$  does not contain any essential surface with nonnegative Euler characteristic. We recall that Kojima has proved in [12] that every hyperbolic manifold with nonempty geodesic boundary admits a *canonical decomposition* into geometric polyhedra.

For any compact 3-manifold  $M$ , an  $\mathbb{N}$ -valued invariant  $c(M)$  was defined by Matveev in [14] and called the *complexity* of  $M$ . Matveev also proved that, when  $M$  is hyperbolic,  $c(M)$  equals the minimal number of tetrahedra in an ideal triangulation of  $M$ .

If  $M$  is a compact 3-manifold with  $\partial M = \partial_0 M \sqcup \partial_1 M$ , one can define the *Heegaard genus* of  $(M, \partial_0 M, \partial_1 M)$  as the minimal genus of a surface

that splits  $M$  as  $C_0 \sqcup C_1$ , where  $C_i$  is obtained by attaching 1-handles on one side of a collar of  $\partial_i M$ .

For any compact 3-manifold  $M$  and integer  $r \geq 2$ , after fixing in  $\mathbb{C}$  a primitive  $2r$ -th root of unity, a real-valued invariant  $\text{TV}_r(M)$  for compact 3-manifolds with boundary was defined by Turaev and Viro in [18].

The following theorem will be proved in Sections 2 and 3.

**Theorem 1.2.** *Let  $M \in \mathcal{M}_{g,k}$ . The following hold:*

1.  $M$  is hyperbolic, and its volume depends only on  $g$  and  $k$ .
2.  $M$  has a unique ideal triangulation with  $g + k$  tetrahedra, which gives the canonical Kojima decomposition of  $M$ .
3. Every essential surface in  $M$  has nonempty boundary which intersects  $\Sigma_g$ .
4.  $M$  has complexity  $g + k$ .
5. The Heegaard genus of  $\left(M, \Sigma_g, \bigsqcup_{i=1}^k T_i\right)$  is  $g + 1$ .
6.  $H_1(M; \mathbb{Z}) = \mathbb{Z}^{g+k}$ .
7. The Turaev-Viro invariant  $\text{TV}_r(M)$  of  $M$  depends only on  $r, g$ , and  $k$ .

**Remark 1.3.** It follows from [16] that  $\mathcal{M}_{g,0}$  is precisely the set of hyperbolic 3-manifolds  $M$  having minimal volume among those with  $\partial M = \Sigma_g$  (see [3]). So  $\mathcal{M}_{g,k}$  is a natural candidate for the set of minimal-volume hyperbolic manifolds  $M$  with  $\partial M = \Sigma_g \sqcup \left(\bigsqcup_{i=1}^k T_i\right)$ .

**Growth of  $\mathcal{M}_{g,k}$**  We begin with the following fact, established in Section 4:

**Proposition 1.4.**  $\mathcal{M}_{g,k}$  is nonempty precisely for  $g > k$  or  $g = k$  and  $g$  even.

We have computed the number of elements of  $\mathcal{M}_{g,k}$  for some small  $g$  and  $k$  with the aid of a computer. Our results are summarized in the next table, where we also take from [4] the number of all hyperbolic manifolds with nonempty geodesic boundary having a certain complexity  $c$ :

	$\mathcal{M}_{c,0}$	$\mathcal{M}_{c-1,1}$	$\mathcal{M}_{c-2,2}$	All hyperbolic manifolds
$c = 2$	8	$\emptyset$	$\emptyset$	8
$c = 3$	74	1	$\emptyset$	151
$c = 4$	2340	12	1	5033
$c = 5$	97568	416	1	?
$c = 6$	?	17900	51	?

We now say that a numerical sequence  $(a_n)_{n=1}^\infty$  has *growth type*  $n^n$  if there exist constants  $C > c > 0$  such that  $n^{c^n} < a_n < n^{C^n}$  for  $n \gg 0$ . In Section 4 we will prove the following:

**Theorem 1.5.** *For any fixed  $k$  the sequence  $(\#\mathcal{M}_{g,k})_{g=2}^\infty$  has growth type  $g^g$ .*

This result and an easy upper bound also established in Section 4 readily imply the following:

**Corollary 1.6.** *The number of hyperbolic 3-manifolds of complexity  $c$  has growth type  $c^c$ .*

**Dehn fillings** Recall that a *slope* in a torus  $T$  is an isotopy class of simple closed essential curves, and that, after choosing a  $\mathbb{Z}$ -basis of  $H_1(T; \mathbb{Z})$ , a slope is represented by a number in  $\mathbb{Q} \cup \{\infty\}$ . If  $M$  is a manifold with  $k$  boundary tori, and  $\alpha_1, \dots, \alpha_h$  are slopes in some  $h \leq k$  of these tori, we denote by  $M(\alpha_1, \dots, \alpha_h)$  the result of Dehn-filling these  $h$  tori along  $\alpha_1, \dots, \alpha_h$ .

For  $g \geq 2$  we now denote by  $H_g$  the handlebody of genus  $g$  and for  $0 \leq k \leq g$  we introduce another manifold  $H_{g,k}$ . We do this noting that  $H_g$  can be viewed as the  $\partial$ -connected sum of  $g$  solid tori, and defining  $H_{g,k}$  to be  $H_g$  minus open tubes around the cores of  $k$  of these solid tori. So  $H_{g,k}$  is obtained from  $H_g$  by drilling out  $k$  tunnels along  $k$  different 1-handles. Of course  $H_{g,k}$  is well-defined and  $H_{g,0} = H_g$ . Moreover,  $H_{g,k}$  is not hyperbolic because it is  $\partial$ -reducible.

The next result is proved in Section 3.

**Theorem 1.7.** *Let  $M \in \mathcal{M}_{g,k}$ , with  $\partial M = \Sigma_g \sqcup \left( \bigsqcup_{i=1}^k T_i \right)$ . There exists a  $\mathbb{Z}$ -basis of  $H_1 \left( \bigsqcup_{i=1}^k T_i; \mathbb{Z} \right)$  such that  $N = M(\alpha_1, \dots, \alpha_h)$  is as follows:*

- If  $\alpha_i \in \{0, 1, \infty\}$  for some  $i$  then  $N = H_{g,k-h}$ , so it is not hyperbolic.
- If  $\alpha_i \in \{-1, 1/2, 2\}$  for some  $i$  then  $N$  contains a Möbius strip or non-separating annulus  $R$  with  $\partial R \subset \Sigma_g$ , and cutting  $N$  along  $R$  one gets  $H_{g,k-h}$ ; also in this case  $N$  is not hyperbolic.
- If  $\alpha_i \notin \{-1, 0, 1/2, 1, 2, \infty\}$  for all  $i$  then  $N$  is hyperbolic and, denoting by  $T_{j_1}, \dots, T_{j_{k-h}}$  the non-filled tori, the Heegaard genus of

$$(N, \Sigma_g, T_{j_1} \sqcup \dots \sqcup T_{j_{k-h}})$$

is  $g + 1$ .

- If  $\alpha_i \in \{-2, -1/2, 1/3, 2/3, 3/2, 3\}$  for all  $i$  then  $N$  belongs to  $\mathcal{M}_{g,k-h}$ .

Moreover every essential surface in  $N$  has nonempty boundary intersecting  $\Sigma_g$ .

If  $\alpha, \alpha'$  are two slopes on a torus, we denote now by  $\Delta(\alpha, \alpha')$  their distance, that is their geometric intersection number. We recall that, once a homology basis is fixed, the set  $\mathbb{Q} \cup \{\infty\}$  of slopes can be viewed as a subset of  $\partial\mathbb{H}^2$ , where  $\mathbb{H}^2$  is the half-space model of hyperbolic plane. Connecting the pairs of slopes  $\alpha, \alpha'$  such that  $\Delta(\alpha, \alpha') = 1$  one gets a tessellation of  $\mathbb{H}^2$  by ideal triangles. A combinatorial (but geometrically incorrect) picture of this tessellation is shown in Figure 1 in the disc model of  $\mathbb{H}^2$ .

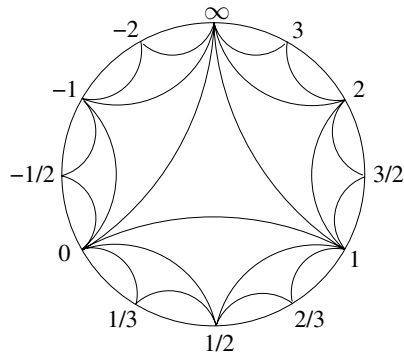

Figure 1: The Farey tessellation of  $\mathbb{H}^2$ .

The theorem just stated gives the following:

**Corollary 1.8.** *For any  $g \geq 2$  there exist infinitely many hyperbolic manifolds  $N$  with  $\partial N = \Sigma_g \sqcup \Sigma_1$  and with 6 slopes  $\alpha^1, \dots, \alpha^6$  on  $\Sigma_1$ , such that  $N(\alpha^i) = H_g$  for  $i \in \{1, 2, 3\}$  and  $N(\alpha^i)$  is annular for  $i \in \{4, 5, 6\}$ . We have  $\Delta(\alpha^i, \alpha^{i+3}) = 2$  for  $i \in \{1, 2, 3\}$ , and  $\Delta(\alpha^j, \alpha^{j'}) = 3$  for  $j, j' \in \{4, 5, 6\}, j \neq j'$ .*

*Proof.* Take  $N = M(\alpha)$  where  $M \in \mathcal{M}_{g,2}$  and  $\alpha$  varies in  $\mathbb{Q} \setminus \{-1, 0, 1/2, 1, 2\}$ . This gives infinitely many manifolds because the volume grows to  $\text{vol}(M)$  as  $\Delta(\alpha, 0)$  tends to infinity. Now let  $(\alpha^1, \dots, \alpha^6) = (0, 1, \infty, 2, -1, 1/2)$ , so  $N(\alpha^i) = H_g$  for  $i \in \{1, 2, 3\}$ . For  $i \in \{4, 5, 6\}$  the manifold  $N(\alpha^i)$  is not hyperbolic, so by Thurston's hyperbolization theorem and the last assertion of Theorem 1.7 it contains either an essential disc or an essential annulus. Since a hyperbolic manifold admits at most 3 boundary-reducible fillings [21], we conclude that  $N(\alpha_i)$  is annular for  $i \in \{4, 5, 6\}$ . q.e.d.

This corollary leads to infinitely many examples of knots in a handlebody  $H_g$  having non-meridinal surgeries that give back  $H_g$  (more precisely, two such surgeries) for all  $g \geq 2$ . For  $g = 1$ , *i.e.* for the solid torus  $H_1$ , knots in  $H_1$  with non-meridinal surgeries giving  $H_1$  were shown to be 1-bridge [7] and then classified by Gabai [8] and Berge [2]. (See Section 3 for a definition of 1-bridge knot). In particular, there is a unique knot in  $H_1$  with two non-meridinal surgeries giving  $H_1$ . A knot in  $H_2$  with one non-meridinal surgery giving  $H_2$  was also shown in [8], and in the same paper other examples in  $H_g$  for any  $g$  were attributed to Berge, together with the following question: if  $K$  is a knot in a  $\partial$ -reducible manifold  $M$  with  $\partial$ -irreducible exterior and a  $\partial$ -reducible non-meridinal surgery, is  $K$  boundary-parallel or 1-bridge in  $M$ ? The answer is “yes” for all the hyperbolic examples one can construct from  $\mathcal{M}_{g,k}$ , as we will show in Section 3:

**Proposition 1.9.** *Every knot in  $H_g$  whose complement is a hyperbolic manifold obtained from  $k - 1$  Dehn fillings on a manifold in  $\mathcal{M}_{g,k}$  is a 1-bridge knot.*

Let  $M$  be a hyperbolic 3-manifold, and  $T_i \subset \partial M$  be a chosen boundary torus. A slope  $\alpha$  on  $T_i$  is called *exceptional* if  $M(\alpha)$  is not hyperbolic. Assuming  $M$  has either some other cusp or nonempty geodesic boundary,  $\alpha$  is exceptional if and only if  $M(\alpha)$  contains an essential sphere, disc, annulus, or torus. In these cases we say that  $\alpha$  is respectively of type  $S$ ,  $D$ ,  $A$ , or  $T$ . For  $X_1, X_2 \in \{S, D, A, T\}$ , we define a number  $\Delta^{\text{hyp}}(X_1, X_2)$  as the maximal distance of two slopes of type  $X_1$  and  $X_2$

in a boundary torus of a hyperbolic manifold [9]. Wu pointed out [22] that in most cases  $\Delta^{\text{hyp}}$  is considerably lower when considering only *large* manifolds, *i.e.* manifolds with  $H_2(M, \partial M \setminus T_i) \neq \{0\}$ . He thus defined  $\Delta^{\text{large}}(X_1, X_2)$  as the maximal distance of two slopes of type  $X_1$  and  $X_2$  in a boundary torus of a *large* hyperbolic manifold. Among other inequalities, he proved that  $1 \leq \Delta^{\text{large}}(D, A) \leq 2$ . Since every hyperbolic manifold  $M$  with  $\chi(M) < 0$  is large, Corollary 1.8 implies that  $\Delta^{\text{large}}(D, A) = 2$ . This result leaves  $\Delta^{\text{large}}(T, T)$  as the only unknown value for  $\Delta^{\text{hyp}}$  and  $\Delta^{\text{large}}$ , as shown in the following tables (which are taken from [9] with the insertion of  $\Delta^{\text{large}}(D, A) = 2$ ).

$\Delta^{\text{hyp}}$	$S$	$D$	$A$	$T$
$S$	1	0	2	3
$D$		1	2	2
$A$			5	5
$T$				8

$\Delta^{\text{large}}$	$S$	$D$	$A$	$T$
$S$	0	0	1	1
$D$		1	2	1
$A$			4	4
$T$				4-5

We now define  $\Delta^{\text{neg}}(X_1, X_2)$  as the maximal distance of two slopes of type  $X_1$  and  $X_2$  in a boundary torus of some hyperbolic manifold  $M$  with  $\chi(M) < 0$ . Of course we have

$$\Delta^{\text{neg}}(X_1, X_2) \leq \Delta^{\text{large}}(X_1, X_2).$$

Gordon and Wu proved in [10] that if two slopes of type  $A$  in a boundary torus of  $M$  have distance greater than 3 then  $M$  is the complement of some link in  $S^3$ . Hence  $\Delta^{\text{neg}}(A, A) \leq 3$ . This estimate and Corollary 1.8 give the following results for  $\Delta^{\text{neg}}$ :

$\Delta^{\text{neg}}$	$D$	$A$
$D$	1	2
$A$		3

More precisely, the values of  $\Delta^{\text{neg}}(X_1, X_2)$  for  $X_1, X_2 \in \{D, A\}$  are realized by every manifold  $M \in \mathcal{M}_{g,k}$  with  $k \geq 1$ , and by every hyperbolic manifold obtained from such an  $M$  by filling some (but not all) boundary components.

**Question 1.10.** What is  $\Delta^{\text{neg}}(X_1, X_2)$  when  $X_1$  is  $S$  or  $T$  ?

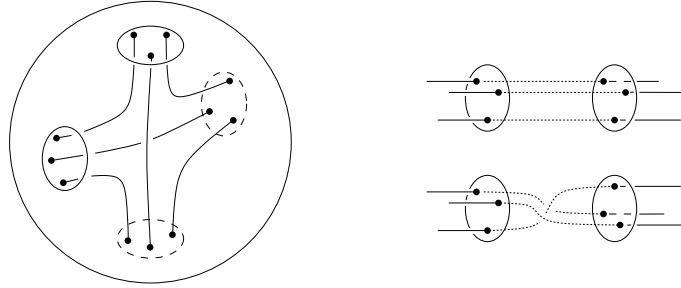

Figure 2: A tangle in a ball (left); a positive and a negative gluing of tangles (right).

**Knots giving  $\mathcal{M}_{g,1}$**  Theorem 1.7 implies that the elements of  $\mathcal{M}_{g,1}$  are knot exteriors in  $H_g$ , and the knots can be exhibited explicitly, as we now explain. Consider a ball  $B$  as in Figure 2-left with the tangle  $\tau \subset B$  as shown, the 12 ends of  $\tau$  being arranged in four groups of three, each group contained in a disc. Now take  $g-1$  copies of  $(B, \tau)$  and glue together the  $4(g-1)$  discs, matching the ends of the  $\tau$ 's. Each gluing should be of one of the two types suggested in Figure 2-right. A gluing as in the top part of Figure 2-right will be called *positive*, one as in the bottom part will be called *negative*. The result of the  $2(g-1)$  gluings is a link in  $H_g$ , and one readily sees that if all the gluings are positive then the link is parallel to  $\partial H_g$ . The following will be proved at the end of Section 3:

**Proposition 1.11.** *If a knot  $K$  in  $H_g$  is realized from  $g-1$  copies of  $(B, \tau)$  with  $2g-3$  positive gluings and one negative gluing then the exterior of  $K$  belongs to  $\mathcal{M}_{g,1}$ . Every manifold in  $\mathcal{M}_{g,1}$  arises like this.*

## 2. Triangulations and hyperbolicity

In this section we discuss some basic properties of the manifolds in  $\mathcal{M}_{g,k}$ . We describe in Proposition 2.2 the properties of a triangulation of a compact manifold  $M$  with  $\partial M = \Sigma_g \sqcup \left( \bigsqcup_{i=1}^k T_i \right)$ , showing in particular that such a triangulation has at least  $g+k$  tetrahedra. This result proves Proposition 1.1 and, together with hyperbolicity of the manifolds in  $\mathcal{M}_{g,k}$ , easily implies point (4) of Theorem 1.2. We then prove all other points of Theorem 1.2, except point (6), which is deferred to Section 3.



Namely, solving the hyperbolicity equations [5] we prove point (1), and using the tilt formula [20, 19, 5] we establish point (2). Next, we use Haken’s theory of normal surfaces to prove point (3), and we show points (5) and (7) by direct arguments.

**Triangulations** Let  $N$  be a compact manifold with boundary and let  $\mathcal{T}$  be an ideal triangulation of  $N$ . We associate to  $\mathcal{T}$  the graph  $\Gamma_{\mathcal{T}}$  whose vertices are the components of  $\partial N$  and whose edges correspond to the edges of  $\mathcal{T}$ . Of course, if  $N$  is connected then  $\Gamma_{\mathcal{T}}$  is also connected.

**Lemma 2.1.** *Let  $N$  be a connected compact manifold with boundary and let  $\mathcal{T}$  be an ideal triangulation of  $N$ . Then  $\chi(\Gamma_{\mathcal{T}}) \leq 0$ . If  $\chi(\Gamma_{\mathcal{T}}) = 0$  then*

$$\Gamma_{\mathcal{T}} = \begin{array}{c} \circ \\ \vdots \\ \circ \end{array} \text{---} \bigcirc$$

and each tetrahedron of  $\mathcal{T}$  has at least three vertices on the component  $C$  of  $\partial N$  having multiple adjacencies in  $\Gamma_{\mathcal{T}}$ .

*Proof.* Each tetrahedron  $\Delta$  determines a subgraph  $\Gamma_{\Delta}$  of  $\Gamma_{\mathcal{T}}$  whose vertices and edges correspond to the vertices and edges of  $\Delta$ , where  $\Delta$  is considered as a subset of  $N$ .

Now suppose  $\chi(\Gamma_{\mathcal{T}}) \geq 0$ . Then  $\chi(\Gamma_{\Delta}) \geq 0$  for every  $\Delta \in \mathcal{T}$ , and this implies that  $\chi(\Gamma_{\Delta})$  is either  $\circ \rightarrow$  or  $\circ$ . Therefore each  $\Delta \in \mathcal{T}$  has at least three vertices on the same component  $C$  of  $\partial N$ . Moreover  $\Gamma_{\mathcal{T}}$  is the union of the  $\Gamma_{\Delta}$ ’s, so it is as required and the conclusion follows. q.e.d.

The following result implies Proposition 1.1. The *incidence number* of an edge in a triangulation is the number of tetrahedra incident to it (with multiplicity).

**Proposition 2.2.** *If  $M$  is connected and  $\partial M = \Sigma_g \sqcup \left( \bigsqcup_{i=1}^k T_i \right)$  then any ideal triangulation  $\mathcal{T}$  of  $M$  has at least  $g + k$  tetrahedra, and if it has  $g + k$  the following hold:*

- $g \geq k$ .
- For any  $i = 1, \dots, k$  there are exactly two tetrahedra of  $\mathcal{T}$  with 3 vertices on  $\Sigma_g$  and one on  $T_i$ ; the remaining  $g - k$  tetrahedra have all 4 vertices on  $\Sigma_g$ .

- $\mathcal{T}$  has  $k+1$  edges  $e_0, \dots, e_k$  such that  $e_0$  has both its endpoints on  $\Sigma_g$  and incidence number  $6g$ , while  $e_i$  connects  $\Sigma_g$  to  $T_i$  and has incidence number 6 for any  $i = 1, \dots, k$ .

*Proof.* If  $\mathcal{T}$  has  $n$  tetrahedra, an Euler characteristic argument shows that it has  $n-g+1$  edges. Therefore  $\chi(\Gamma_{\mathcal{T}}) = 1+k-(n-g+1) = k+g-n$ . Lemma 2.1 then implies that  $n \geq k+g$ , and that if  $n = k+g$  there exists a component  $C$  of  $\partial M$  such that every tetrahedron has at least 3 vertices on  $C$ . Moreover  $\mathcal{T}$  has  $k+1$  edges. Let  $y$  be the number of tetrahedra of  $\mathcal{T}$  having some (and then one) vertex on  $\partial M \setminus C$ .

We first claim that  $C = \Sigma_g$ . Note that  $\mathcal{T}$  induces on  $\partial M \setminus C$  a triangulation with  $k$  vertices and  $y$  triangles. If  $C \neq \Sigma_g$ , we would have  $2-2g = \chi(\partial M \setminus C) = k-y/2$ , whence  $y+4 = 4g+2k = 2(g+k)+2g \geq y+(g+k)+2g$  and  $4 \geq 3g+k$ . Since  $g \geq 2$ , this is a contradiction and our claim is proved.

Having shown that  $C = \Sigma_g$ , we get  $0 = \chi(\partial M \setminus C) = k-y/2$ , so  $y = 2k$ . Therefore the triangulation of  $\partial M$  induced by  $\mathcal{T}$  has exactly one vertex and two triangles on each  $T_i$ . So for any  $i = 1, \dots, k$  two tetrahedra of  $\mathcal{T}$  have one vertex in  $T_i$ . These  $2k$  tetrahedra are distinct, so  $n = g+k \geq 2k$ , whence  $g \geq k$ . Moreover there is only one edge  $e_i$  of  $\mathcal{T}$  incident to  $T_i$ , both tetrahedra incident to  $T_i$  are triply incident to  $e_i$ , and no other tetrahedron is incident to  $e_i$ . So all  $e_i$ 's have incidence number 6, and the other edge  $e_0$  has incidence number  $6(g+k)-6k = 6g$ , because a tetrahedron has 6 edges. q.e.d.

We now turn to the proof of Theorem 1.2.

**Geometric tetrahedra** We prove here Theorem 1.2-(1). In order to construct a hyperbolic structure on our manifold  $M \in \mathcal{M}_{g,k}$  we realize the tetrahedra of an ideal triangulation of  $M$  as special geometric blocks in  $\mathbb{H}^3$  and then we require that the structures match under the gluings. To describe the blocks to be used we need some definitions.

A *partially truncated tetrahedron* is a pair  $(\Delta, \mathcal{I})$ , where  $\Delta$  is a tetrahedron and  $\mathcal{I}$  is a set of vertices of  $\Delta$ , which are called *ideal vertices*. In the sequel we will always refer to  $\Delta$  itself as a partially truncated tetrahedron, tacitly implying that  $\mathcal{I}$  is also fixed. The *topological realization*  $\Delta^*$  of  $\Delta$  is obtained by removing from  $\Delta$  the ideal vertices and small open stars of the non-ideal ones. We call *lateral hexagon* and *truncation triangle* the intersection of  $\Delta^*$  respectively with a face of  $\Delta$  and with the link in  $\Delta$  of a non-ideal vertex. The edges of the truncation

triangles, which also belong to the lateral hexagons, are called *boundary edges*, and the other edges of  $\Delta^*$  are called *internal edges*. Note that, if  $\Delta$  has ideal vertices, a lateral hexagon of  $\Delta^*$  may not quite be a hexagon, because some of its (closed) boundary edges may be missing. A *geometric realization* of  $\Delta$  is an embedding of  $\Delta^*$  in  $\mathbb{H}^3$  such that the truncation triangles are geodesic triangles, the lateral hexagons are geodesic polygons with ideal vertices corresponding to missing edges, and the truncation triangles and lateral hexagons lie at right angles to each other. The classification of the geometric realizations of partially truncated tetrahedra given in [5] implies the following facts:

- Let  $\Delta$  be a partially truncated tetrahedron with one ideal vertex  $v_0$ , and take  $\alpha \in \mathbb{R}$  with  $0 < \alpha < \pi/3$ . Then there exists, up to isometry, exactly one geometric realization of  $\Delta$  with dihedral angles  $\pi/3$  along the internal edges emanating from  $v_0$ , and angle  $\alpha$  along the other internal edges; this geometric partially truncated tetrahedron will be denoted by  $\Delta_\alpha^{\text{id}}$  (where “id” stands for “ideal”).
- Let  $\Delta$  be a partially truncated tetrahedron without ideal vertices and take  $\alpha \in \mathbb{R}$  with  $0 < \alpha < \pi/3$ . Then there exists, up to isometry, exactly one geometric realization of  $\Delta$  with all the dihedral angles along the internal edges equal to  $\alpha$ ; this geometric truncated tetrahedron will be denoted by  $\Delta_\alpha^{\text{reg}}$  (where “reg” stands for “regular”).

**Consistency** Let  $M$  be our manifold in  $\mathcal{M}_{g,k}$ , and let  $\mathcal{T}$  be an ideal triangulation of  $M$  with  $g+k$  tetrahedra. We try to give  $M$  a hyperbolic structure with geodesic boundary by realizing the tetrahedra of  $\mathcal{T}$  as copies of the geometric polyhedra just described. More precisely, we know from Proposition 2.2 that  $\mathcal{T}$  consists of  $2k$  tetrahedra with one vertex on the boundary tori and  $g-k$  tetrahedra with all the vertices on  $\Sigma_g$ . So we fix  $\alpha, \beta \in (0, \pi/3)$ , we realize the tetrahedra incident to the boundary tori of  $M$  as  $2k$  copies of  $\Delta_\alpha^{\text{id}}$  and the tetrahedra incident only to  $\Sigma_g$  as  $g-k$  copies of  $\Delta_\beta^{\text{reg}}$ .

It was shown in [5] that the hyperbolic structure given on the tetrahedra of  $\mathcal{T}$  extends to the whole of  $M$  if and only if all the matching boundary edges have the same length and the total dihedral angle around each internal edge is  $2\pi$ . Suppose first that  $1 \leq k \leq g-1$ . In this case the length condition translates into the equation  $f(\alpha, \beta) = 0$ ,

where

$$f(\alpha, \beta) = \frac{\cos^2 \alpha + 1/2}{\sin^2 \alpha} - \frac{\cos^2 \beta + \cos \beta}{\sin^2 \beta},$$

while, by Proposition 2.2, the total dihedral angle condition gives the equation

$$6k \cdot \alpha + 6(g - k) \cdot \beta = 2\pi.$$

Now let  $\beta(\alpha) = \frac{\pi - 3k \cdot \alpha}{3(g - k)}$  be the solution of this equation. Setting  $\phi(\alpha) = f(\alpha, \beta(\alpha))$  we easily get that  $\lim_{\alpha \rightarrow 0} \phi(\alpha) = +\infty$ ,  $\lim_{\alpha \rightarrow \pi/3k} \phi(\alpha) = -\infty$ .

Moreover,  $\phi$  is strictly monotonic on  $(0, \pi/3k)$  so the length and total angle equations have a unique solution  $(\bar{\alpha}_{g,k}, \bar{\beta}_{g,k})$  in  $(0, \pi/3) \times (0, \pi/3)$ . This solution determines a hyperbolic structure with geodesic boundary on  $M$ .

When  $k = 0$  or  $k = g$  the situation is even simpler, and the scheme just described easily extends. More precisely, when  $k = 0$  only compact geometric polyhedra arise, so the shape of the tetrahedra of  $\mathcal{T}$  is parametrized by  $\beta$  and the hyperbolicity condition is verified for  $\bar{\beta}_{g,0} = \pi/3g$ . On the other hand, when  $k = g$  every tetrahedron of  $\mathcal{T}$  has a vertex on a boundary torus, so the geometric realizations of  $\mathcal{T}$  are parametrized by  $\alpha$  and the hyperbolicity condition gives  $\bar{\alpha}_{g,g} = \pi/3g$ .

**Completeness** To check completeness of the hyperbolic structure just described we have to determine the similarity structure it induces on the boundary tori. By construction, each torus in  $\partial M$  is tiled by two equilateral Euclidean triangles. This shows that the structures on the boundary tori are indeed Euclidean, so the hyperbolic structure constructed in the previous paragraph is complete, and corresponds by Mostow’s rigidity theorem to the *unique* complete finite-volume hyperbolic structure with geodesic boundary on the topological manifold  $M$  with the boundary tori removed. The volume of  $M$  is  $2k \cdot \text{Vol} \left( \Delta_{\bar{\alpha}_{g,k}}^{\text{id}} \right) + (g - k) \cdot \text{Vol} \left( \Delta_{\bar{\beta}_{g,k}}^{\text{reg}} \right)$ , which depends on  $g$  and  $k$  only. We have eventually proved Theorem 1.2-(1).

**Canonical decomposition** We now establish Theorem 1.2-(2). Kojima proved in [12] that a complete finite-volume hyperbolic manifold  $M$  with nonempty geodesic boundary admits a *canonical decomposition* into partially truncated polyhedra (an obvious generalization of a partially truncated tetrahedron). This decomposition is obtained by projecting first to  $\mathbb{H}^3$  and then to  $M$  the faces of the convex hull of a

certain family  $\mathcal{P}$  of points in Minkowsky 4-space. This family  $\mathcal{P}$  splits as  $\mathcal{P}' \sqcup \mathcal{P}''$ , with  $\mathcal{P}'$  consisting of the points on the hyperboloid  $\|x\|^2 = +1$  which are dual to the hyperplanes giving  $\partial\widetilde{M}$ , where  $\widetilde{M} \subset \mathbb{H}^3$  is a universal cover of  $M$ . The points in  $\mathcal{P}''$  lie on the light-cone, and they are the duals of horoballs projecting in  $M$  to Margulis neighbourhoods of the cusps. The choice of these Margulis neighbourhoods is somewhat tricky, and carefully explained in [5]. It will be sufficient for our present purposes to know that any choice of sufficiently small Margulis neighbourhoods leads to a set  $\mathcal{P}''$  which works. Note in particular that, when there is more than one cusp, the Margulis neighbourhoods need not have the same volume, as required for instance for the canonical Epstein-Penner decomposition [6]. In the sequel we will denote by  $\mathcal{O}$  the union of sufficiently small Margulis neighbourhoods of the cusps.

**Tilts** Suppose a geometric triangulation  $\mathcal{T}$  of  $M$  is given. The matter of deciding if  $\mathcal{T}$  is the canonical Kojima decomposition of  $M$  is faced using the *tilt formula* [20, 19, 5], that we now briefly describe.

Let  $\sigma$  be a  $d$ -simplex in  $\mathcal{T}$  and  $\tilde{\sigma}$  be a lifting of  $\sigma$  to  $\widetilde{M} \subset \mathbb{H}^3$ . To each end of  $\tilde{\sigma}$  there corresponds (depending on the nature of the end) one horoball in the lifting of  $\mathcal{O}$  or one hyperbolic plane in the boundary of  $\widetilde{M}$ , so  $\tilde{\sigma}$  determines  $d + 1$  points of  $\mathcal{P}$ . Now let two tetrahedra  $\Delta_1$  and  $\Delta_2$  share a 2-face  $F$ , and let  $\tilde{\Delta}_1, \tilde{\Delta}_2$  and  $\tilde{F}$  be liftings of  $\Delta_1, \Delta_2$  and  $F$  to  $\widetilde{M} \subset \mathbb{H}^3$  such that  $\tilde{\Delta}_1 \cap \tilde{\Delta}_2 = \tilde{F}$ . Let  $\overline{F}$  be the 2-subspace in Minkowsky 4-space that contains the three points of  $\mathcal{P}$  determined by  $\tilde{F}$ . For  $i = 1, 2$  let  $\overline{\Delta}_i^{(F)}$  be the half-3-subspace bounded by  $\overline{F}$  and containing the fourth point of  $\mathcal{P}$  determined by  $\tilde{\Delta}_i$ . Then one can show that  $\mathcal{T}$  is canonical if and only if, whatever  $F, \Delta_1, \Delta_2$ , the following holds:

- The half-3-subspaces  $\overline{\Delta}_1^{(F)}$  and  $\overline{\Delta}_2^{(F)}$  lie on distinct 3-subspaces and their convex hull does not contain the origin of Minkowsky 4-space.

The tilt formula computes a real number  $t(\Delta, F)$  describing the “slope” of  $\overline{\Delta}^{(F)}$ . More precisely, one can translate the condition just stated into the inequality

$$t(\Delta_1, F) + t(\Delta_2, F) < 0.$$

Coming to the manifolds we are interested in, let  $M \in \mathcal{M}_{g,k}$ , let  $\mathcal{T}$  be a geometric triangulation of  $M$  by  $g + k$  partially truncated tetrahedra

as described above and let  $\mathcal{O}$  be a suitable neighbourhood of the cusps of  $M$ . It was shown in [5] that  $\mathcal{O}$  determines a real number  $r_\Delta(v) > 0$  for any ideal vertex  $v$  of any tetrahedron  $\Delta$  in  $\mathcal{T}$ . This number  $r_\Delta(v)$  represents the “height” of the trace in  $\Delta$  near  $v$  of  $\partial\mathcal{O}$  (except that  $r_\Delta(v) \ll 1$  means that  $\partial\mathcal{O}$  is “very” high).

Recall now that in  $\mathcal{T}$  all the tetrahedra having vertices in the cusps have only one such vertex and are isometric to each other. It follows that we can choose  $\mathcal{O}$  so that  $r_\Delta(v)$  has a certain value  $r$  whenever  $v$  is an ideal vertex of some  $\Delta$  in  $\mathcal{T}$ . Using the formulae given in [5] we can now easily compute the tilts of the geometric blocks of  $\mathcal{T}$ .

- Let  $v_0$  be the ideal vertex of  $\Delta_\alpha^{\text{id}}$  and let  $r = r(v_0)$  be the parameter associated to the intersection of  $\Delta_\alpha^{\text{id}}$  with  $\mathcal{O}$ . If  $F_0$  is the face of  $\Delta_\alpha^{\text{id}}$  opposite to  $v_0$  and  $F_1$  is any other face of  $\Delta_\alpha^{\text{id}}$ , then

$$\begin{aligned} t(\Delta_\alpha^{\text{id}}, F_0) &= r/(2 \cos \alpha) - \sqrt{4 \cos^2 \alpha - 1}, \\ t(\Delta_\alpha^{\text{id}}, F_1) &= -r/2. \end{aligned}$$

- If  $F$  is any face of  $\Delta_\beta^{\text{reg}}$ , then

$$t(\Delta_\beta^{\text{reg}}, F) = -\sqrt{\frac{(3 \cos \beta - 1)(2 \cos \beta - 1)}{\cos \beta + 1}}.$$

If  $r$  is small enough, we then get  $t(\Delta_1, F_1) + t(\Delta_2, F_2) < 0$  for any pair  $(F_1, F_2)$  of matching faces of  $\mathcal{T}$ , and this suffices to prove that  $\mathcal{T}$  is the Kojima canonical decomposition of  $M$ . Therefore there is only one triangulation of  $M$  with  $g+k$  tetrahedra. We have proved Theorem 1.2-(2).

**Normal surfaces** We now prove Theorem 1.2-(3) using Haken’s theory of normal surfaces [14]. Let  $\mathcal{T}$  be the ideal triangulation of  $M$  with  $g+k$  vertices. Suppose  $S \subset M$  is a properly embedded incompressible and  $\partial$ -incompressible surface not intersecting  $\Sigma_g$ . Then  $S$  can be isotoped into normal position with respect to  $\mathcal{T}$  (by hyperbolicity,  $S$  cannot be a sphere or a disc, and  $M$  is irreducible). The surface  $S$  intersects each tetrahedron having 4 truncation triangles in  $\Sigma_g$  in internal triangles and squares, and it intersects each tetrahedron with 1 truncation triangle in some boundary torus  $T_i$  in internal triangles, squares, and squares having one edge in  $T_i$  as in Figure 3-(1). We prove that

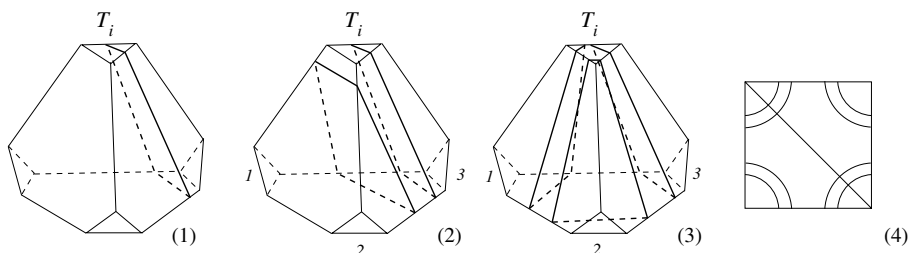

Figure 3: Types of intersection between a normal surface and a tetrahedron.

only internal triangles are permitted, which implies that  $S$  is boundary-parallel, hence not essential.

Let us first consider a tetrahedron  $\Delta$  with one truncation triangle in some  $T_i$ . Suppose first there are  $q_1 > 0$  internal squares. One type of square intersecting  $T_i$  can also be present, as shown in Figure 3-(2). Let  $q_2$  be the number of parallel copies of such squares. We enumerate the three truncation triangles of  $\Delta$  not on  $T_i$  by 1, 2, and 3 and we denote by  $t_j$  the number of triangles in  $S \cap \Delta$  that are parallel to the  $j$ -th truncation triangle. The three base edges connecting vertices 1, 2, and 3 are glued together, therefore we have

$$t_1 + t_2 = t_2 + q_2 + q_1 + t_3 = t_1 + q_2 + q_1 + t_3$$

which implies that  $t_1 = t_2 = q_1 + q_2 + t_3$ . The three other edges are also glued together, whence  $t_1 + q_1 = t_3$ , a contradiction. This shows that there are no internal squares. Then  $S$  can contain three types of squares intersecting  $T_i$ , as shown in Figure 3-(3), and we denote by  $q_1, q_2$ , and  $q_3$  the number of parallel copies of each type. As above, we have two equations, namely

$$t_1 + t_2 + q_1 + q_2 = t_2 + t_3 + q_2 + q_3 = t_3 + t_1 + q_3 + q_1,$$

$$t_1 = t_2 = t_3,$$

giving  $q_1 = q_2 = q_3$ . Then  $\partial S \cap T_i$  consists of  $q_1$  copies of the trivial loop, as in Figure 3-(4): a contradiction, since  $S$  is incompressible.

The case where  $\Delta$  has all truncation triangles in  $\Sigma_g$  is easier: only triangles and squares are allowed, and all six edges of  $\Delta$  are glued together. Writing equations as above we get that there is no square.

**Matveev complexity and Heegaard genus** Theorem 1.2-(4), which states that  $c(M) = g + k$  for  $M \in \mathcal{M}_{g,k}$ , is now an easy consequence of Proposition 1.1 together with the fact [14] that, because of hyperbolicity,  $c(M)$  equals the minimal number of tetrahedra in an ideal triangulation of  $M$ .

The genus of  $\left(M, \Sigma_g, \bigsqcup_{i=1}^k T_i\right)$  is of course at least  $g$ , and it is actually at most  $g + 1$  because, if  $e$  is the only edge of the minimal triangulation of  $M$  having both ends in  $\Sigma_g$ , the boundary of a regular neighborhood of  $\Sigma_g \cup e$  is easily seen to be a Heegaard surface. The next result, together with the fact that  $H_{g,k}$  is not hyperbolic, shows that the genus is indeed  $g + 1$ .

**Lemma 2.3.** *If  $M$  is compact with  $\partial M = \Sigma_g \sqcup \left(\bigsqcup_{i=1}^k T_i\right)$  and  $\left(M, \Sigma_g, \bigsqcup_{i=1}^k T_i\right)$  has genus  $g$  then  $M = H_{g,k}$ .*

*Proof.*  $M$  is obtained by attaching 1-handles to  $\left(\bigsqcup_{i=1}^k T_i\right) \times [0, 1]$  along  $\left(\bigsqcup_{i=1}^k T_i\right) \times \{1\}$  until a boundary component  $\Sigma_g$  is created. Viewing  $T_i \times [0, 1]$  as the collar of the boundary of a solid torus, we see that  $M$  can also be described as follows:

- Attach 1-handles to a disjoint union of  $k$  solid tori until a connected manifold with one boundary component  $\Sigma_g$  is created.
- Drill the cores of the original  $k$  solid tori.

At the end of the first step we obviously have  $H_g$ , so we have  $H_{g,k}$  at the end of the second step. q.e.d.

**Turaev-Viro invariants** We conclude this section proving Theorem 1.2-(7). As pointed out in [15], Turaev-Viro invariants depend only on incidence numbers between edges and tetrahedra in a triangulation. In our context, let us consider the minimal triangulation  $\mathcal{T}$  of some  $M$  in  $\mathcal{M}_{g,k}$ . If we assign the colour 0 to the edge having both endpoints in  $\Sigma_g$ , and colours  $\{1, \dots, k\}$  to the other edges, then the 6 edges of each of the  $g + k$  tetrahedra in  $\mathcal{T}$  are coloured. It is clear that this set of  $g + k$  coloured tetrahedra is the same for each  $M \in \mathcal{M}_{g,k}$ . This implies that all such  $M$ 's have the same Turaev-Viro invariants.



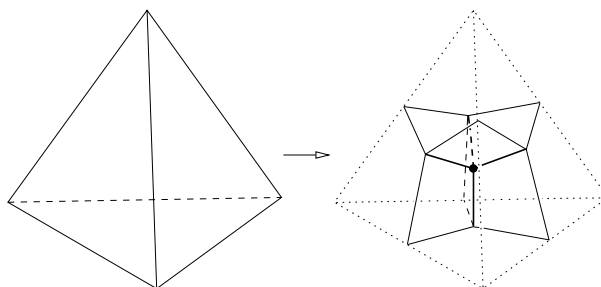

Figure 4: From an ideal triangulation to a standard spine.

### 3. Spines and Dehn filling

We prove here Theorem 1.2-(6), Theorem 1.7, Proposition 1.9 and Proposition 1.11. To do this, we switch from the viewpoint of ideal triangulations to the dual viewpoint of *standard spines*, suggested in Figure 4. Recall that a spine of a manifold is a subpolyhedron onto which the manifold collapses. A polyhedron is *standard* if it is locally homeomorphic to that of Figure 4-right and its natural stratification consists of 0-, 1-, and 2-cells. We will be tacitly using in the sequel some of Matveev’s theory of spines [14], but we actually will not need to cite any precise result: we will try to reconstruct all we need in an elementary and self-contained way.

Let us then fix  $M \in \mathcal{M}_{g,k}$  and the spine  $P$  dual to the triangulation of  $M$  with  $g + k$  tetrahedra. Note that  $P$  has a cellularization into vertices, edges, and faces corresponding to tetrahedra, faces, and edges of the triangulation. We denote in particular by  $S(P)$  the 1-skeleton of  $P$  (a 4-valent graph). By Proposition 2.2 the spine  $P$  contains  $k$  (open) hexagonal faces  $F_1, \dots, F_k$  and one big face  $G$  with  $6g$  vertices (with multiplicity). For  $i = 1, \dots, k$  the closure  $\overline{F}_i$  of  $F_i$  is a torus which bounds a collar of the  $i$ -th toric component  $T_i$  of  $\partial M$ , and the rest of  $P$  lies outside this collar.

**Homology** We prove Theorem 1.2-(6). The case  $k = 0$  was dealt with in [3], so we suppose  $k > 0$ . Since  $M$  collapses onto  $P$ , we have  $H_1(M; \mathbb{Z}) \cong H_1(P; \mathbb{Z})$ , and we can use cellular homology to compute  $H_1(P; \mathbb{Z})$ . Since  $\overline{F}_i$  intersects  $S(P)$  in a  $\theta$ -shaped graph, there is a maximal tree  $Y$  in the 4-valent graph  $S(P)$  intersecting each  $\overline{F}_i$  in an edge. Then  $S(P) \setminus Y$  consists of  $g + k + 1$  edges  $e_1, \dots, e_{g+k+1}$ , where  $e_{2i-1}$

and  $e_{2i}$  are contained in  $\overline{F_i}$  for  $i = 1, \dots, k$ , while  $e_{2k+1}, \dots, e_{g+k+1}$  are contained in  $\overline{G}$ . Choosing an orientation on each  $e_j$ ,  $F_i$ , and  $G$ , we get a presentation for  $H_1(P)$  with generators  $e_1, \dots, e_{g+k+1}$  and relators given by the incidence numbers of  $G$  and the  $F_i$ 's on the  $e_j$ 's. Each  $F_i$  contributes with the trivial relator  $e_{2i-1} + e_{2i} - e_{2i-1} - e_{2i}$ , while  $G$  contributes with a big relator  $w$  containing  $e_1$  once. Therefore  $H_1(P; \mathbb{Z}) = \mathbb{Z}^{g+k+1} / \langle w \rangle \cong \mathbb{Z}^{g+k}$ .

**Dehn fillings** We prove here Theorem 1.7, starting from the case  $h = 1$  (the general case will easily follow). Let then  $\alpha$  be a slope on the boundary torus  $T_1$  corresponding to  $\overline{F_1}$ . It is easy to construct a spine  $P(\alpha)$  for  $M(\alpha)$ : the complement of  $P \subset M \subset M(\alpha)$  inside  $M(\alpha)$  consists of the disjoint union of  $\Sigma_g \times [0, 1)$ ,  $k - 1$  copies of  $\Sigma_1 \times [0, 1)$ , and one open solid torus. Take a meridional disc  $D$  of this solid torus. The complement of  $P \cup D$  is as above, with an open ball instead of the open solid torus. The loop  $\partial D \subset \overline{F_1}$  cuts  $F_1$  into some open faces of  $P \cup D$  (see two examples in Figure 5 below). Each such face separates  $\Sigma_g \times [0, 1)$  from the open ball, so, if we remove the face, we get a spine  $P(\alpha)$  of  $M(\alpha)$ .

The  $\theta$ -shaped graph  $S(P) \cap \overline{F_1}$  contains three loops, representing three slopes with pairwise intersection one, having coordinates 0, 1, and  $\infty$  with respect to an appropriate basis of  $H_1(T; \mathbb{Z})$ . Let us consider the case  $\alpha$  is 0, 1, or  $\infty$ . In the construction sketched above of a spine of  $M(\alpha)$ , we can ask  $\partial D$  to lie inside the  $\theta$ -shaped graph  $S(P) \cap \overline{F_1}$ . The face  $F_1$  then survives in  $P \cup D$ , hence  $P(\alpha) = (P \cup D) \setminus F_1$  is a spine of  $M(\alpha)$ . Now  $P(\alpha)$  has an induced stratification with 1-dimensional stratum  $S(P)$ , and 2-dimensional stratum consisting of the  $k - 1$  faces  $F_2, \dots, F_k$ , the face  $G$  and the disc  $D$ . Note now that there is one edge of  $P(\alpha)$ , namely the edge of  $S(P) \cap \overline{F_1}$  not contained in  $\partial D$ , which was previously adjacent twice to  $F_1$  and once to  $G$ , which is now only adjacent once to  $G$ . Therefore  $P(\alpha)$  can be collapsed starting from this edge, and in this collapse the 2-dimensional strata  $G$  and  $D$  disappear. The resulting polyhedron is still a spine of  $M(\alpha)$ , and is made of  $k - 1$  tori  $\overline{F_2}, \dots, \overline{F_k}$  and some 1-dimensional strata, *i.e.* a graph connecting these tori. An orientable manifold having such a spine is necessarily a boundary connected sum of a handlebody and some  $\Sigma_1 \times I$ . Since  $\partial M(\alpha)$  consists of one  $\Sigma_g$  and  $k - 1$  tori, we have  $M(\alpha) = H_{g, k-1}$ , as required.

We consider now the case  $\alpha \in \{-1, 1/2, 2\}$ . The slope  $\alpha$  is repre-

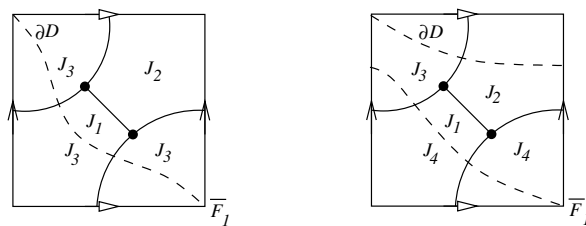

Figure 5: A slope in  $\{-1, 1/2, 1\}$  (left) or in  $\{-2, -1/2, 1/3, 2/3, 3/2, 3\}$  (right) is represented by a loop  $\partial D$  intersecting transversely  $S(P) \cap \overline{F_1}$  in two (left) or three (right) points.

sented by a loop  $\partial D$  which intersects transversely the graph  $S(P) \cap \overline{F_1}$  in two points, as in Figure 5-left. Consider the (open) face  $J_1 \subset \overline{F_1}$  shown in Figure 5-left. The spine  $P(\alpha) = (P \cup D) \setminus J_1$  of  $M(\alpha)$  has an induced stratification with  $S(P) \cup \partial D$  as 1-dimensional stratum and the faces  $F_2, \dots, F_k, G, J_2, J_3$ , and  $D$  as 2-dimensional strata. However this is not the intrinsic stratification of  $P(\alpha)$ , because each of the four edges that were adjacent to  $J_1$  is now adjacent to a pair of faces only, so the four edges and the faces incident to them can be merged into a single 2-dimensional stratum  $S$ . The pairs of faces incident to the edges of  $J_1$  are  $\{J_3, G\}$ ,  $\{J_2, G\}$ ,  $\{J_3, G\}$ , and  $\{J_3, D\}$ , therefore  $S$  is either an annulus or a Möbius strip. Let us consider its core  $\gamma$ . Taking the pre-image of  $\gamma$  under the projection from  $M(\alpha)$  to  $P(\alpha)$  we get an annulus or Möbius strip  $R$  properly embedded in  $M(\alpha)$  with  $\partial R \subset \Sigma_g$  and intersecting  $P(\alpha)$  in  $\gamma$ . Moreover, cutting  $M(\alpha)$  and  $P(\alpha)$  along  $R$  and  $\gamma$  respectively, we get a manifold  $M'$  and a spine of  $M'$  which retracts onto  $P(\alpha) \setminus S$ . This polyhedron is easily seen to be connected, so  $M'$  is connected, i.e.,  $R$  is non-separating. In addition,  $P(\alpha) \setminus S$  consists of the tori  $\overline{F_2}, \dots, \overline{F_k}$  and some graph connecting them, which implies as above that  $M' = H_{g,k-1}$ . Consider now the manifold  $D(M(\alpha))$  obtained by mirroring  $M(\alpha)$  in  $\Sigma_g$ , and note that it is hyperbolic if  $M(\alpha)$  is. Now  $R$  gives a closed non-separating surface  $D(R)$  in  $D(M(\alpha))$ , and  $D(R)$  is homeomorphic either to the torus or to the Klein bottle. Such a surface cannot exist in a hyperbolic manifold, so  $M(\alpha)$  is not hyperbolic.

If  $\alpha$  is none of the slopes studied above, then by Thurston's geometrization theorem either  $M(\alpha)$  is hyperbolic or it contains an essential surface of nonnegative Euler characteristic. Theorem 1.2-(3), now proved, implies that  $M(\alpha)$  does not contain any closed essential

surface. To conclude we now refer to the bounds on  $\Delta^{\text{large}}$  stated in Section 1. The fact that the slopes  $0, 1, \infty$  are of type  $D$  and the bound  $\Delta^{\text{large}}(D, D) \leq 1$  imply that  $\alpha$  cannot be of type  $D$ . The same fact and the bound  $\Delta^{\text{large}}(D, A) \leq 2$  imply that  $\alpha$  cannot be of type  $A$ , and hyperbolicity of  $M(\alpha)$  follows. Moreover  $M(\alpha)$  has genus  $g+1$ , because the genus- $(g+1)$  Heegaard surface of  $M$  is a Heegaard surface also for  $M(\alpha)$ , and  $M(\alpha)$  cannot have genus  $g$  by Lemma 2.3.

Finally, suppose  $\alpha \in \{-2, -1/2, 1/3, 2/3, 3/2, 3\}$ . The slope  $\alpha$  is represented by a loop  $\partial D$  intersecting transversely the graph  $S(P) \cap \overline{F_1}$  in three points, as in Figure 5-right. As above, we take  $P(\alpha) = (P \cup D) \setminus J_1$ . The edges that were adjacent to  $J_1$  are now adjacent to the four pairs of faces  $\{J_3, G\}$ ,  $\{J_2, G\}$ ,  $\{J_4, G\}$ , and  $\{J_4, D\}$ . We can therefore as above take a stratification with a 4-valent graph as 1-stratum and discs  $F_2, \dots, F_k, D'$  as 2-strata, where  $D'$  is the disc obtained by merging  $J_2, J_3, J_4, G$ , and the four edges of  $J_1$ . Now  $P(\alpha)$  is standard, so it can be dualized to an ideal triangulation of  $M(\alpha)$  with  $k$  edges and  $g+k-1$  tetrahedra. Therefore  $M(\alpha) \in \mathcal{M}_{g,k-1}$ , as required.

The case  $h > 1$  follows from the case  $h = 1$ , using the fact that  $H_{g,k}(\alpha) = H_{g,k-1}$  for all slopes  $\alpha$ , and repeating the same argument above to prove that if  $\alpha_i \notin \{-1, 0, 1/2, 1, 2, \infty\}$  for all  $i$  then the filled manifold is hyperbolic. The last assertion of Theorem 1.7 is a direct consequence of Theorem 1.2-(3), so the proof of 1.7 is now complete.

**Remark 3.1.** The construction used in the proof of Theorem 1.7 to pass from  $P$  to  $P(\alpha)$  can actually be generalized [13] to any slope  $\alpha$ . The idea is to note that  $P \setminus F_1$  has a natural  $\theta$ -shaped “boundary,” and to take a spine  $Q_\alpha$  of the filling solid torus  $H_1$  so that  $Q_\alpha$  also has a  $\theta$ -shaped “boundary” on  $\partial H_1$ , and the gluing of  $\partial H_1$  to  $T_1$  (determined by  $\alpha$ ) matches  $\partial Q_\alpha$  to  $\partial(P \setminus F_1)$ . If  $\alpha \in \{0, 1, \infty\}$  the polyhedron  $Q_\alpha$  is a meridional disc with a longitudinal arc in  $\partial H_1$ , as in Figure 6-(1). If  $\alpha \in \{-1, 1/2, 2\}$  the polyhedron  $Q_\alpha$  is the Möbius triplet shown in Figure 6-(2). If  $\alpha \notin \{-1, 0, 1/2, 1, 2, \infty\}$ , one has to change the  $\theta$ -shaped boundary of the Möbius triplet via some *flips* (see Figure 6-(3,4)), each flip adding a vertex to  $Q_\alpha$  as in Figure 6-(5).

The construction of  $P(\alpha)$  as  $Q_\alpha \cup (P \setminus F_1)$  is “efficient,” in the sense that if  $P$  has a minimal number of vertices, then  $P(\alpha)$  very often does. This construction is actually dual to adding a layered solid torus to a triangulation, but it is important to notice that spines often display greater flexibility than triangulations. For instance, the construction of  $P(\alpha)$  described in the proof when  $\alpha \in \{0, 1, \infty\}$  has no analogue

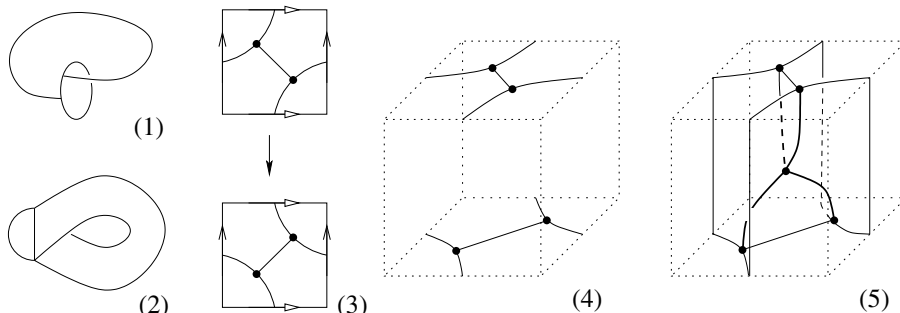

Figure 6: Two spines of the solid torus (1,2) and a flip (3,4) realized by adding a vertex (5).

for triangulations, is usually efficient, and always produces a spine with strictly fewer vertices than  $P$ . This is coherent with the fact that the slopes  $\alpha \in \{0, 1, \infty\}$  are often exceptional, so they give a manifold  $M(\alpha)$  which is simpler than  $M$ . Other natural properties of spines that triangulations do not have are shown in [14].

**1-bridge knots** We now turn to Proposition 1.9. A knot  $K$  in a manifold  $M$  is 1-bridge if it can be isotoped to the form  $\gamma_0 \cup \gamma_1$  where the  $\gamma_i$ 's are simple arcs with common ends,  $\gamma_0$  lies on  $\partial M$ , and  $\gamma_1$  is properly embedded and parallel to  $\partial M$  [8].

To prove Proposition 1.9, let  $N$  be the exterior of a knot  $K$  contained in the interior of  $H_g$ , and assume  $N$  is hyperbolic and homeomorphic to some  $M(\alpha_1, \dots, \alpha_{k-1})$  for  $M \in \mathcal{M}_{g,k}$ . Let  $P$  be the spine of  $M$  dual to the triangulation with  $g + k$  tetrahedra. Since  $P$  is contained in  $M(\alpha_1, \dots, \alpha_{k-1})$  we can view  $P$  as a subset of  $H_g$ . Recall now that  $P$  contains  $k$  disjoint hexagonal faces, whose closures are tori, and one big face  $G$ . Let  $\overline{F_1}$  be the hexagonal face parallel to the only torus in  $\partial N$ : the torus  $\overline{F_1}$  has  $K$  on one side and the whole of  $P$  on the other side. The graph  $S(P) \cap \overline{F_1}$  has the shape of a  $\theta$ , so it contains three slopes. Filling along any of these slopes we get  $H_g$ , so the bound  $\Delta^{\text{large}}(D, D) \leq 1$  implies, as in the above proof of Theorem 1.7, that the meridian of  $K$  must be one of the slopes contained in  $\theta$ .

Let us now take in  $\overline{F_1}$  two loops  $s$  and  $s'$  so that  $s'$  is isotopic to the meridian of  $K$  and  $s$  is isotopic to a different slope contained in  $\theta$ . We also arrange so that  $s$  and  $s'$  intersect each other and  $\theta$  transversely in a single point, as in Figure 7-(1). The points  $p = s \cap \theta$  and  $p' = s' \cap \theta$  lie in

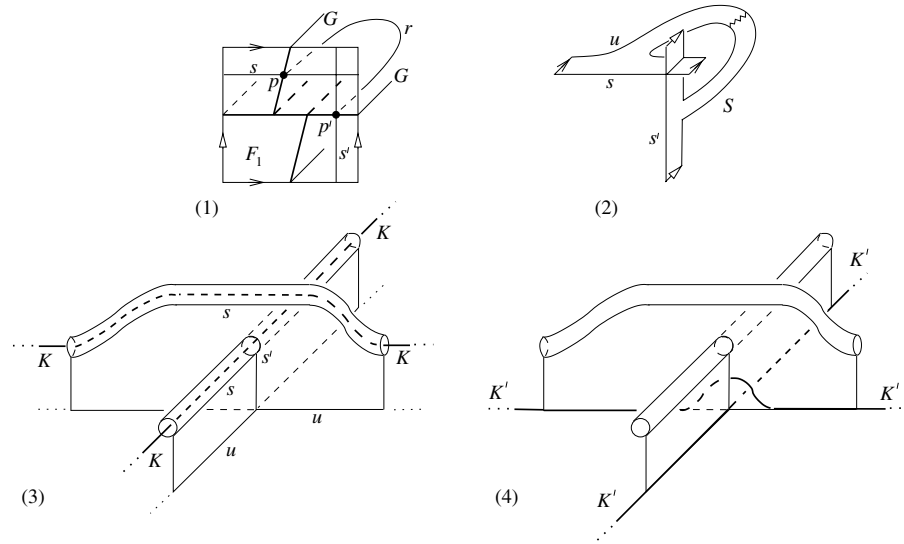

Figure 7: Isotoping a knot to 1-bridge position.

the boundary of the big face  $G$ , so there is an arc  $r$  properly embedded in  $G$  connecting them, also shown in Figure 7-(1). The inverse image of the graph  $s \cup r \cup s'$  under the retraction of  $M$  onto  $P$  is a set  $S$  as in Figure 7-(2), where a half-twist of the strip may or not be present along the zig-zagged segment. In either case, one easily sees that  $S$  is a properly immersed pair of pants with  $\partial S = s \cup s' \cup u$ , where  $u$  is an immersed loop in  $\Sigma_g$  with one self-intersection. Since  $s'$  is a meridian of  $K$ , the surface  $S$  appears in the exterior of  $K$  in  $H_g$  as in Figure 7-(3). In part (4) of the same figure we suggest how to isotope  $K$  to a knot  $K'$  in 1-bridge position.

**Knots giving  $\mathcal{M}_{g,1}$**  We prove here Proposition 1.11. Let  $K$  be a knot in  $H_g$  constructed with one negative gluing. We prove that the exterior of  $K$  in  $H_g$  lies in  $\mathcal{M}_{g,1}$  by constructing for it a standard spine with  $g + 1$  vertices. Later we will prove that the unique minimal spine of each manifold in  $\mathcal{M}_{g,1}$  is the result of one such construction, for some  $K$ . A spine of the exterior of  $K$  is constructed by taking a portion as shown in Figure 8-left for each of the  $g - 1$  tangles. These portions can be attached (with some torsion) at each positive gluing, while the piece shown in Figure 8-right must be inserted at the single negative

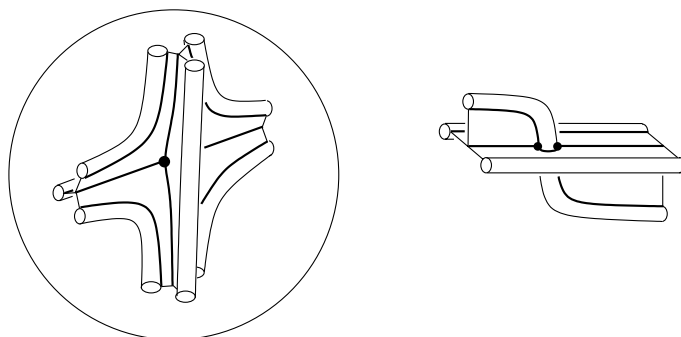

Figure 8: Portions of spine of the knot exterior.

gluing. The resulting polyhedron is a standard spine of the exterior of  $K$  and has  $(g - 1) + 2$  vertices, as required. Standardness comes from the fact that  $K$  is a *knot*, rather than a link, and from the presence of one portion as in Figure 8-right.

Now let  $M$  be a manifold in  $\mathcal{M}_{g,1}$  and let  $P$  be the spine dual to the triangulation of  $M$  with  $g + 1$  tetrahedra. The spine  $P$  has one open hexagonal face  $F_1$  (whose closure is a torus) and one big open face  $G$  with  $6g$  vertices. The graph  $\overline{F_1} \cap S(P)$  has the shape of a  $\theta$ , and we denote it by  $\theta$ . We choose one of its edges, say  $e$ , and distinct points  $w_1, \dots, w_{6g-3}$  in the interior of  $e$ . We denote by  $e_1, \dots, e_{2g-1}$  the edges of  $S(P)$  not contained in  $\theta$ , and choose an inner point  $v_i$  in each  $e_i$ . As an abstract face,  $G$  is a  $6g$ -gon with one edge  $\tilde{e}$  incident to  $e$ , two other edges incident to  $\theta$ , and  $6g - 3$  more edges, divided into groups of three incident to the same  $e_i$ . Let  $\tilde{w}_k$  be the point of  $\tilde{e}$  incident to  $w_k$ , and  $\tilde{v}_i^{(1)}, \tilde{v}_i^{(2)}, \tilde{v}_i^{(3)}$  be the points on  $\partial G$  incident to  $v_i$ . Now choose  $6g - 3$  pairwise disjoint arcs in  $G$  each having one  $\tilde{w}_k$  and one  $\tilde{v}_i^{(j)}$  as its ends. The image in  $P$  of the union of these arcs is a disjoint union of  $2g - 1$  graphs, each having the shape of a  $Y$  with all three endpoints on  $e$ . Choose now  $6g - 3$  parallel circles in the torus  $\overline{F_1}$ , each intersecting  $\theta$  in one of the  $w_k$ 's. Attach these circles to the  $Y$ -shaped graphs, getting  $2g - 1$  graphs with shape  $\begin{array}{c} \circ \\ \diagup \quad \diagdown \\ \circ \end{array}$ . It is now not difficult to see that, cutting along these graphs, one gets  $g - 1$  polyhedra as in Figure 8-left and one polyhedron as in Figure 8-right. (The special portion is the one which contains the two edges of  $\theta$  other than  $e$ ). From this decomposition one readily sees that  $P$  arises as explained above for some knot in  $H_g$  constructed with one negative gluing, so  $M$  is the exterior of this knot.

#### 4. Growth estimates

This section is devoted to the proof of Proposition 1.4 and Theorem 1.5. Estimates of the form  $\#\mathcal{M}_{g,0} \geq a \cdot b^g$  were already obtained in [3]. We first improve this result, and then we extend it to  $\mathcal{M}_{g,k}$  for any fixed  $k$ .

**Theorem 4.1.** *The sequence  $(\#\mathcal{M}_{g,0})_{g=2}^\infty$  has growth type  $g^g$ .*

Recall that  $M \in \mathcal{M}_{g,0}$  if and only if it is orientable and admits a 1-edged ideal triangulation with  $g$  tetrahedra, and that this triangulation is unique. To prove Theorem 4.1 we introduce the set  $\mathcal{G}_n$  of homeomorphism classes of connected 4-valent graphs with  $n$  vertices, and we denote by  $\mathcal{G}'_n$  the graphs in  $\mathcal{G}_n$  arising as dual skeleta of one-edged triangulations of orientable manifolds, so that  $\#\mathcal{M}_{n,0} \geq \#\mathcal{G}'_n$ . And we prove the following:

**Proposition 4.2.** *The sequence  $(\#\mathcal{G}_n)_{n=1}^\infty$  has growth type  $n^n$ .*

**Proposition 4.3.** *For all  $n$  there exists a map  $\phi_n : \mathcal{G}_{n-1} \rightarrow \mathcal{G}'_n$  such that  $\phi_n(G)$  is obtained by adding a curl at some internal point of an edge of  $G$ .*

Assuming these results the proof of Theorem 4.1 is now easy. Note that if  $G \in \mathcal{G}_n$  then  $G$  contains at most  $n$  curls. So  $\#(\phi_n^{-1}(G)) \leq n$  for  $G \in \mathcal{G}'_n$ . In particular  $\#\mathcal{G}'_n \geq \frac{1}{n} \cdot \#\mathcal{G}_{n-1}$ , and the conclusion readily follows from Proposition 4.2 and the next easy:

**Remark 4.4.** There are at most  $18^n$  distinct orientable triangulations with a given dual 1-skeleton.

*Proof of 4.2.* This result is purely graph-theoretical, and its proof is not hard. Let us imagine a 4-valent graph with  $n$  vertices as being constructed from the disjoint union of  $n$  crosses  $\text{+}$  by joining together in pairs the  $4n$  free germs of edges. If we fix an ordering on these  $4n$  germs, there are  $4n - 1$  choices for the germ to be joined to the first germ, then  $4n - 3$  for the next free germ, and so on, whence  $(4n - 1)!!$  in all. This is however too rough a counting, because disconnected graphs may arise. But the final graph is disconnected if and only if at some point along the construction process a subgraph without free germs of edges is created. Assume this happens at time  $i$ . For the final edge of the saturated subgraph there is only one choice, so all other  $4n - 2i$  choices do not create saturated subgraphs. This easily implies that at least  $(4n - 2)!!$  different construction patterns lead to connected graphs.



We must now consider that different construction patterns can lead to homeomorphic graphs. Since there are  $n$  vertices of valence 4, one readily sees that at most  $(4!)^n \cdot n!$  different patterns can lead to the same graph. This implies that

$$(4n - 1)!! \geq \#\mathcal{G}_n \geq \frac{(4n - 2)!!}{(4!)^n \cdot n!}.$$

Now the easy inequalities  $\sqrt{(k + 1)!} \geq k!! \geq \sqrt{k!}$  and Stirling’s formula imply that

$$\begin{aligned} & \left( \sqrt{8\pi n} \left( \frac{4n}{e} \right)^{4n} e^{1/48n} \right)^{1/2} \\ & \geq \#\mathcal{G}_n \\ & \geq \frac{\left( \sqrt{2\pi(4n - 2)} \left( \frac{4n - 2}{e} \right)^{4n - 2} \right)^{1/2}}{(4!)^n \sqrt{2\pi n} (n/e)^n e^{1/12n}} \end{aligned}$$

and the conclusion readily follows.

q.e.d.

To establish Proposition 4.3 we begin with the following:

**Lemma 4.5.** *For all  $G \in \mathcal{G}_n$  there exists an orientable ideal triangulation with dual graph  $G$  and at most two edges.*

*Proof.* We adopt the dual viewpoint of orientable standard spines, so we assume  $P$  is a spine such that  $S(P) = G$  and the number  $m$  of faces of  $P$  is the minimal possible one, and we show that  $m \leq 2$ .

Recall now that  $P$  is determined by a regular neighbourhood  $U(S(P))$  of the singular set  $S(P)$ , because  $\partial U(S(P))$  consists of the attaching circles of the faces of  $P$ . Moreover, as in [1], one can represent  $P$  in the plane by drawing  $\partial U(S(P))$  only. To establish the conclusion we first prove three claims, each showing that if  $P$  has “too many” faces then a new  $P$  with fewer faces and the same  $S(P)$  can be constructed, which contradicts minimality.

*Claim 1:* if  $e$  is an edge of  $S(P)$ , the three faces of  $P$  running along  $e$  cannot be distinct from each other. This is shown in Figure 9.

*Claim 2:* if two faces run along an edge, the face running twice cannot run in opposite directions, as proved in Figure 10.

*Claim 3:* no face can run twice along two edges with different companions. This is proved in Figure 11 (note that Claim 2 is used to draw the picture).

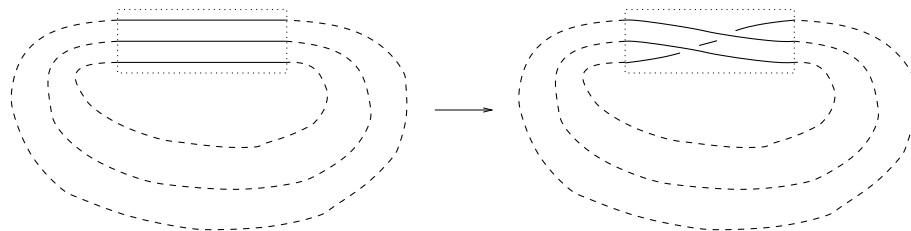

Figure 9: Left: if three different faces of  $P$  run along the edge  $e$  shown in the dotted box, their attaching circles in the rest of  $\partial U(S(P))$  are connected as shown. Right: this modification of  $U(P)$  near  $e$  reduces the number of faces.

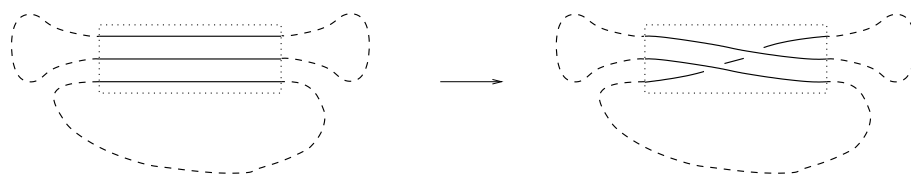

Figure 10: If a face passes twice with a counterpass, the number of faces can be reduced.

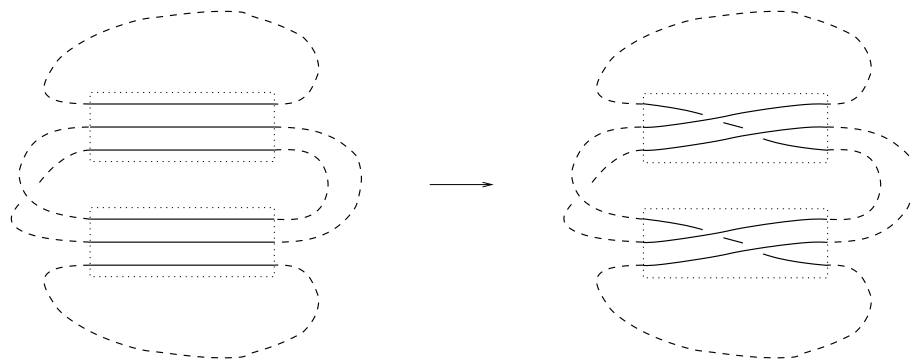

Figure 11: If a face passes twice along two edges with different companions, the number of faces can be reduced.

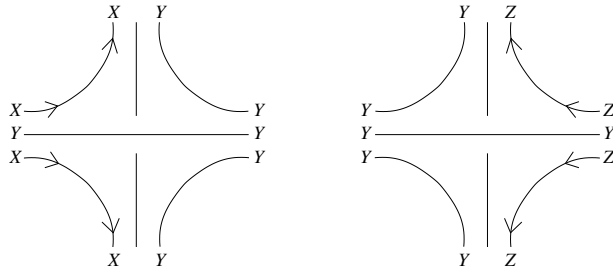

Figure 12: Conclusion of the proof.

We can now conclude. Supposing  $P$  has at least three faces, it is easy to see that there is a simple path  $e_1 \cdots e_k$  of edges of  $S(P)$  such that the total number of faces touching  $e_1 \cup e_k$  is at least three. Now suppose  $k$  is minimal, let  $e_1$  be touched by faces  $XXY$  (claim 1 is used here) and  $e_k$  be touched by some  $Z \neq X, Y$ . We suppose  $k \geq 3$ , leaving the easier case  $k = 2$  as an exercise to the reader. Minimality of  $k$  and Claim 3 imply that  $e_2$  is touched either by  $XXX$  or by  $YYY$ , and actually that the same face  $X$  or  $Y$  must be triply incident to all  $e_2, \dots, e_{k-1}$ . Claim 3 now implies that one of the following must happen:

1.  $e_1 = XXY, e_2 = \cdots = e_{k-1} = XXX, e_k = XZZ$ ;
2.  $e_1 = XXY, e_2 = \cdots = e_{k-1} = YYY, e_k = YYZ$ ;
3.  $e_1 = XXY, e_2 = \cdots = e_{k-1} = YYY, e_k = YZZ$ .

Cases (1) and (2) are symmetric, so we treat (2). By Claim 2, at the end of  $e_1$ , the situation is as in Figure 12-left. Since  $e_k$  is touched by  $YYZ$ , Claim 3 shows that the missing label must be  $X$ , but then Claim 2 would be violated: a contradiction. Case (3) is similar. At the end of  $e_1$  we still have the pattern of Figure 12-left, and Claim 2 shows that the missing label must be  $Y$ . Now the beginning of  $e_k$  is as in Figure 12-right, so the missing label again must be  $Y$ . Then we would have edges  $XYY$  and  $ZYY$ , violating Claim 3. q.e.d.

*Proof of 4.3.* The definition of  $\phi(G)$  is different depending on whether  $G$  belongs to  $\mathcal{G}'_{n-1}$  or not. If  $G \notin \mathcal{G}'_{n-1}$  we consider an orientable standard spine  $P$  based on  $G$  and having two faces. The previous proof implies that there is an edge of  $G$  along which a face of  $P$  passes twice in the same direction. Then we build a new  $P$  as in Figure 13, and call

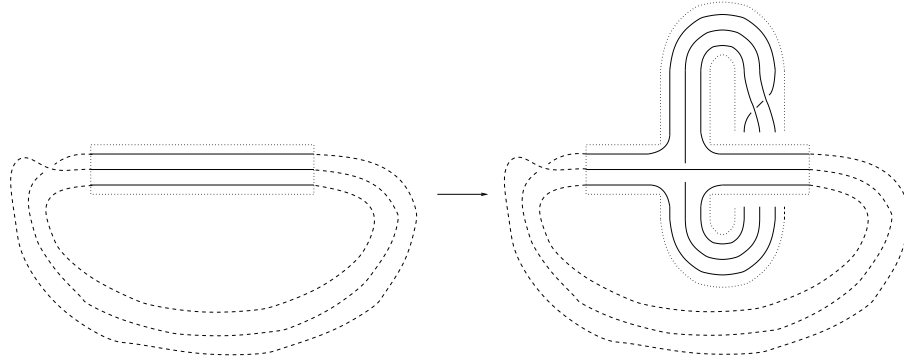

Figure 13: Left: attaching circles of faces outside an edge where a face passes twice. Right: a spine with one face and one more vertex.

$\phi_n(G)$  its singular set. If  $G \in \mathcal{G}'_{n-1}$  we choose  $P$  with one face. Looking at any vertex we see that there must be an edge along which the face runs twice in one direction and once in the opposite direction. Then we define  $\phi_n(G)$  as in Figure 14. q.e.d.

*Proof of 1.4 and 1.5.* We have already proved in Proposition 2.2 that  $\mathcal{M}_{g,k}$  is empty whenever  $g < k$ . We also know that if  $P$  is a spine with  $g + k$  vertices of some  $M \in \mathcal{M}_{g,k}$  then up to isotopy  $P$  contains the boundary tori  $T_1, \dots, T_k$ , and a neighbourhood in  $P$  of  $T_i$  is as in Figure 15-left.

Therefore if  $g = k$  then  $S(P)$  must be as in Figure 15-right. This implies that  $\mathcal{M}_{g,g}$  is nonempty if and only if there exists a spine  $P$  of an orientable manifold having  $S(P)$  as in Figure 15-right and a total of  $g + 1$  faces with  $g$  of them as in Figure 15-left. Using the techniques of [1] it is now easy to see that such a  $P$  exists if and only if  $g$  is even.

We now turn to the case  $g > k$ . It was proved in [3] that  $\mathcal{M}_{g,0}$  is nonempty for all  $g \geq 2$ , and in [4] that  $\mathcal{M}_{2,1}$  is also nonempty. We will now construct for  $g > k$  a function  $\psi : \mathcal{M}_{g,k} \rightarrow \mathcal{M}_{g+1,k+1}$ , whose existence then implies that  $\mathcal{M}_{g,k}$  is nonempty for all  $g > k$ . We will also prove that  $\#\psi^{-1}(M) \leq 3g$  for all  $M$ , which, using Theorem 4.1, proves that for fixed  $k$  the growth type of  $(\#\mathcal{M}_{g,k})_{g=k}^\infty$  is  $g^g$ .

Let us then construct  $\psi$ . Let  $M \in \mathcal{M}_{g,k}$  and let  $P$  be its spine with  $g + k$  vertices. Since  $g > k$ , there is one vertex  $v$  of  $P$  which does not belong to the closure of any hexagonal face, so it is adjacent to the big face  $G$  only. Among the 4 edges incident to  $v$  there is certainly

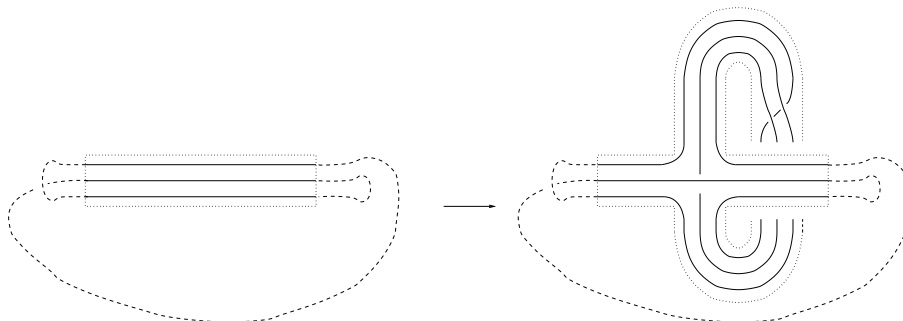

Figure 14: Left: attaching circle of the face outside an edge where it passes three times but not in the same direction. Right: a spine with one face and one more vertex.

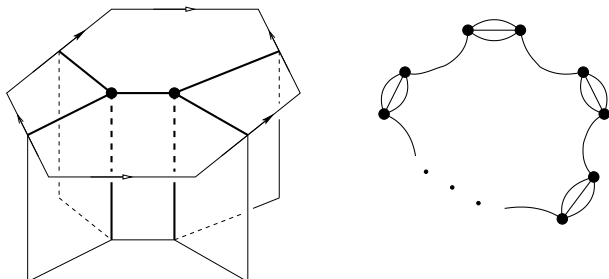

Figure 15: Spines of elements of  $\mathcal{M}_{g,g}$ .

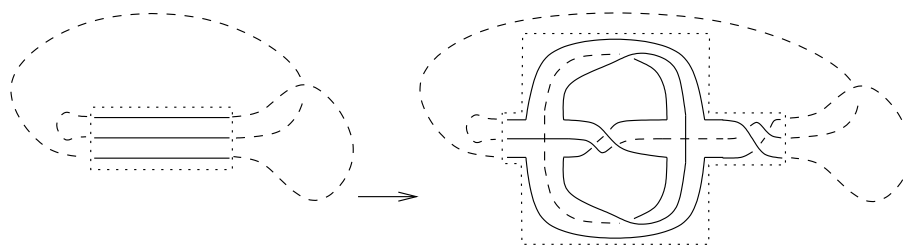

Figure 16: How to transform a spine of  $M \in \mathcal{M}_{g,k}$  to a spine of  $M' \in \mathcal{M}_{g+1,k+1}$ .

one edge along which  $G$  runs twice in one direction and once in the opposite one, as in Figure 16-left. With the move shown in Figure 16 we get a polyhedron  $P'$  with one big face,  $g + 1$  hexagons and  $g + k + 2$  vertices. Such a polyhedron is then a spine of a manifold  $M' = \psi(M) \in \mathcal{M}_{g+1, k+1}$ . To show that  $\#\psi^{-1}(M') \leq 3g$  we recall that  $M'$  has a unique minimal spine  $P'$  and note that there are  $k + 1 \leq g$   $\theta$ -shaped portions of  $P'$  that we can delete and, after deletion, we have at most 3 ways to connect what is left. q.e.d.

### References

- [1] R. Benedetti & C. Petronio, *A finite graphic calculus for 3-manifolds*, Manuscripta Math. **88** (1995) 291-310, [MR 96m:57008](#), [Zbl 0856.57009](#).
- [2] J. Berge, *The knots in  $D^2 \times S^1$  which have nontrivial Dehn surgeries that yield  $D^2 \times S^1$* , Topology Appl. **39** (1991) 1–19, [MR 92d:57005](#), [Zbl 0725.57001](#).
- [3] R. Frigerio, B. Martelli & C. Petronio, *Complexity and Heegaard genus of an infinite class of compact 3-manifolds*, Pacific J. Math. **210** (2003) 283–297.
- [4] R. Frigerio, B. Martelli & C. Petronio, *Small hyperbolic 3-manifolds with geodesic boundary*, [math.GT/0211425](#).
- [5] R. Frigerio & C. Petronio, *Construction and recognition of hyperbolic 3-manifolds with geodesic boundary*, [math.GT/0109012](#), to appear in Trans. Amer. Math. Soc.
- [6] D.B.A. Epstein & R.C. Penner, *Euclidean decompositions of noncompact hyperbolic manifolds*, J. Differential Geom. **27** (1988) 67–80, [MR 89a:57020](#), [Zbl 0611.53036](#).
- [7] D. Gabai, *Surgery on knots in solid tori*, Topology **28** (1989) 1–6, [MR 90h:57005](#), [Zbl 0678.57004](#).
- [8] D. Gabai, *1-bridge braids in solid tori*, Topology Appl. **37** (1990) 221–235, [MR 92b:57011](#), [Zbl 0817.57006](#).
- [9] C.McA. Gordon, *Small surfaces and Dehn filling*, in ‘Proceedings of the Kirbyfest’ (Berkeley, CA, 1998), 177-199 (electronic), Geometry and Topology Monographs, Vol. 2, Coventry, 1999, [MR 2000j:57036](#), [Zbl 0948.57014](#).
- [10] C.McA. Gordon & Y.Q. Wu, *Annular Dehn fillings*, Comment. Math. Helv. **75**(3) (2000) 430–456, [MR 2001j:57024](#), [Zbl 0964.57020](#).
- [11] C.McA. Gordon & Y.Q. Wu, *Annular and boundary reducing Dehn fillings*, Topology **39** (2000) 531–548, [MR 2001b:57033](#), [Zbl 0944.57014](#).

- [12] S. Kojima, *Polyhedral decomposition of hyperbolic manifolds with boundary*, Proc. Work. Pure Math. **10** (1990) 37–57.
- [13] B. Martelli & C. Petronio, *3-manifolds up to complexity 9*, Experiment. Math. **10** (2001) 207–236, [MR 2002f:57045](#).
- [14] S.V. Matveev, *Complexity theory of three-dimensional manifolds*, Acta Appl. Math. **19** (1990), 101–130, [MR 92e:57029](#), [Zbl 0724.57012](#).
- [15] S.V. Matveev & T. Nowik, *On 3-manifolds having the same Turaev-Viro invariants*, Russian J. Math. Phys. **2** (1994) 317–324, [MR 96a:57043](#), [Zbl 0911.57014](#).
- [16] Y. Miyamoto, *Volumes of hyperbolic manifolds with geodesic boundary*, Topology **33** (1994) 613–629, [MR 95h:57014](#), [Zbl 0824.53038](#).
- [17] K. Miyazaki & K. Motegi, *Toroidal and annular Dehn surgeries of solid tori*, Topology Appl. **93** (1999) 173–178, [MR 2000e:57011](#), [Zbl 0930.57014](#).
- [18] V.G. Turaev & O. Viro, *State sum invariants of 3-manifolds and quantum 6j-symbols*, Topology **31** (1992) 865–902, [MR 94d:57044](#), [Zbl 0779.57009](#).
- [19] A. Ushijima, *The tilt formula for generalized simplices in hyperbolic space*, Discrete Comput. Geom. **28** (2002) 19–27, [MR 2003b:57023](#), [Zbl 1011.51016](#).
- [20] J.R. Weeks, *Convex hulls and isometries of cusped hyperbolic 3-manifolds*, Topology Appl. **52** (1993) 127–149, [MR 95a:57021](#), [Zbl 0808.57005](#).
- [21] Y.Q. Wu, *Incompressibility of surfaces in surgered 3-manifolds*, Topology **31** (1992) 271–279, [MR 94e:57027](#), [Zbl 0872.57022](#).
- [22] Y.Q. Wu, *Sutured manifold hierarchies, essential laminations, and Dehn surgery*, J. Differential Geom. **48** (1998) 407–437, [MR 99h:57043](#), [Zbl 0917.57015](#).

SCUOLA NORMALE SUPERIORE  
PIAZZA DEI CAVALIERI 7  
I-56127 PISA, ITALY

DIPARTIMENTO DI MATEMATICA APPLICATA  
UNIVERSITÀ DI PISA  
VIA BONANNO PISANO 25B  
I-56126 PISA, ITALY

DIPARTIMENTO DI MATEMATICA APPLICATA  
UNIVERSITÀ DI PISA  
VIA BONANNO PISANO 25B  
I-56126 PISA, ITALY